



US007304842B2

(12) **United States Patent**
Yatskov

(10) **Patent No.:** **US 7,304,842 B2**
(45) **Date of Patent:** **Dec. 4, 2007**

(54) **APPARATUSES AND METHODS FOR COOLING ELECTRONIC DEVICES IN COMPUTER SYSTEMS**

5,323,847 A 6/1994 Koizumi et al.
5,329,425 A * 7/1994 Leyssens et al. 361/701
5,339,214 A 8/1994 Nelson

(75) Inventor: **Alexander I. Yatskov**, Seattle, WA (US)

(Continued)

FOREIGN PATENT DOCUMENTS

(73) Assignee: **Cray Inc.**, Seattle, WA (US)

EP 1665916 3/2005

(*) Notice: Subject to any disclaimer, the term of this patent is extended or adjusted under 35 U.S.C. 154(b) by 0 days.

(Continued)

OTHER PUBLICATIONS

(21) Appl. No.: **11/153,847**

Vogel, Martin et al., "Low Profile Heat Sink Cooling Technologies for Next Generation CPU Thermal Designs," *Electronic Cooling Online*, 2002-2005, 11 pages.

(22) Filed: **Jun. 14, 2005**

(Continued)

(65) **Prior Publication Data**

Primary Examiner—Jayprakash Gandhi

US 2005/0286230 A1 Dec. 29, 2005

Assistant Examiner—Ingrid Wright

(74) *Attorney, Agent, or Firm*—Perkins Coie LLP

Related U.S. Application Data

(57) **ABSTRACT**

(60) Provisional application No. 60/579,401, filed on Jun. 14, 2004.

Apparatuses and methods for cooling processors and other electronic components in computers and other systems are disclosed herein. A heat sink configured in accordance with one embodiment of the invention includes a heat pipe structure. The heat pipe structure includes an interface portion offset from a body portion by a leg portion. The interface portion is configured to be positioned proximate to a processor or other electronic device, and the body portion is configured to be spaced apart from the electronic device. The heat pipe structure further includes a working fluid. The working fluid is positioned to absorb heat from the electronic device at the interface portion of the heat pipe structure and transfer the heat to the body portion of the heat pipe structure. In one embodiment, the heat sink can further include a plurality of cooling fins attached to the body portion of the heat pipe structure.

(51) **Int. Cl.**
H05K 7/20 (2006.01)

(52) **U.S. Cl.** **361/687**; 165/80.3; 361/697

(58) **Field of Classification Search** 361/687-704, 361/709-712, 717-720; 165/80.3

See application file for complete search history.

(56) **References Cited**

U.S. PATENT DOCUMENTS

- 3,317,798 A 5/1967 Chu et al.
- 4,315,300 A 2/1982 Parmerlee et al.
- 4,993,482 A 2/1991 Dolbear et al.
- 5,035,628 A 7/1991 Casciotti et al.
- 5,150,277 A 9/1992 Bainbridge et al.
- 5,161,087 A 11/1992 Frankeny et al.
- 5,273,438 A 12/1993 Bradley

23 Claims, 9 Drawing Sheets

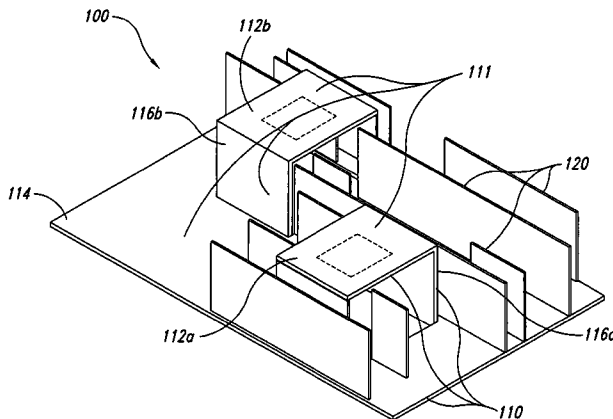

U.S. PATENT DOCUMENTS

5,365,402 A 11/1994 Hatada et al.
 5,376,008 A 12/1994 Rodriguez
 5,395,251 A 3/1995 Rodriguez et al.
 5,402,313 A 3/1995 Casperson et al.
 5,410,448 A 4/1995 Barker, III et al.
 6,046,908 A 4/2000 Feng
 6,115,242 A 9/2000 Lambrecht
 6,158,502 A 12/2000 Thomas
 6,167,948 B1 1/2001 Thomas
 6,310,773 B1 10/2001 Yusuf et al.
 6,332,946 B1 12/2001 Emmett et al.
 6,416,330 B1 7/2002 Yatskov
 6,435,266 B1 8/2002 Wu
 6,515,862 B1 2/2003 Wong et al.
 6,519,955 B2 * 2/2003 Marsala 62/119
 6,550,530 B1 * 4/2003 Bilski 165/104.26
 6,564,858 B1 5/2003 Stahl
 6,644,384 B2 11/2003 Stahl
 6,661,660 B2 * 12/2003 Prasher et al. 361/700
 6,679,081 B2 1/2004 Marsala
 6,772,604 B2 8/2004 Bash et al.
 6,914,780 B1 * 7/2005 Shanker et al. 361/687
 6,975,510 B1 12/2005 Robbins et al.
 6,992,889 B1 1/2006 Kashiwagi et al.
 6,997,245 B2 * 2/2006 Lindemuth et al. 165/104.26
 6,999,316 B2 * 2/2006 Hamman 361/701
 2001/0052412 A1 12/2001 Tikka
 2002/0181200 A1 12/2002 Chang
 2003/0056941 A1 3/2003 Lai et al.
 2004/0008491 A1 1/2004 Chen
 2004/0052052 A1 3/2004 Rivera
 2005/0120737 A1 6/2005 Borrer et al.
 2005/0162834 A1 7/2005 Nishimura
 2005/0168945 A1 8/2005 Coglitore

2005/0241810 A1 11/2005 Malone et al.

FOREIGN PATENT DOCUMENTS

JP 2004-079754 8/2002

OTHER PUBLICATIONS

Webb, Warren, "Take the heat: Cool that hot embedded design," *EDN*, May 13, 2004, 5 pages.
 "Heat Spreaders," Novel Concepts, Inc., <http://www.novelconceptsinc.com/heat-spreaders.htm>, accessed Jun. 14, 2005, 3 pages.
 "Therma-base™ Heat Sink," Thermacore, <http://www.thermacore.com/thermabase.htm>, accessed Jun. 14, 2005, 3 pages.
 Baer, D.B., "Emerging Cooling Requirements & Systems in Telecommunications Spaces," Telecommunications Energy Conference 2001, Oct. 14-18, 2001, pp. 95-100.
 "Frequently Asked Questions about Heat Pipes," Thermacore International, Inc., http://www.thermacore.com/hpt_faqs.htm, 3 pages [accessed Jun. 14, 2004].
 Hannemann, Robert et al., "Pumped Liquid Multiphase Cooling," ASME, 2004, IMECE 2004, Paper IMECE2004-60669, Anaheim, CA, 5 pages.
 "Heat Spreaders," Novel Concepts, Inc., <http://www.novelconceptsinc.com/heat-spreaders.htm>, 2 pages [accessed Jun. 14, 2004].
 JAMSTEC/Earth Simulator Center, "Processor Node (PN) Cabinet," one page <http://www.es.jamstec.go.jp/esc/eng/Hardware/pnc.html> [accessed Mar. 5, 2004].
 Pitasi, M. "Thermal Management System Using Pumped Liquid R-134a with Two Phase Heat Transfer," Thermal Form & Function LLC, Manchester, MA, http://www.coolingzone.com/Guest/News/NL_MAR_2002/TFP/Tff.html, pp. 1-9, Mar. 2002.

* cited by examiner

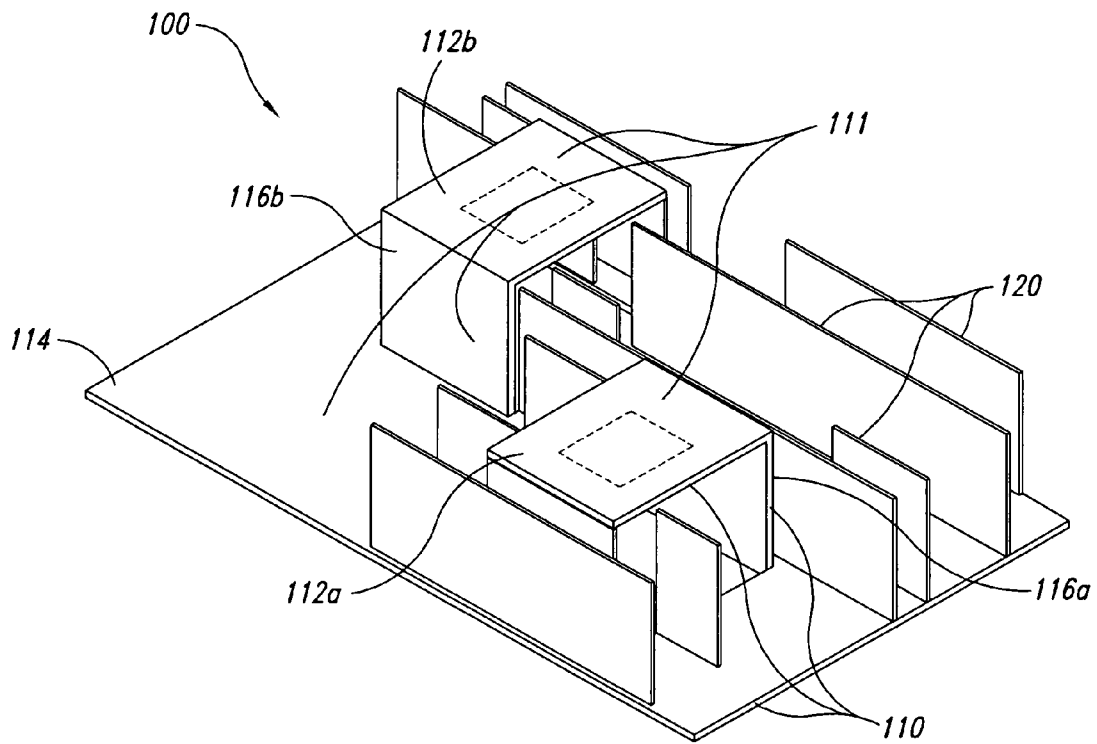

Fig. 1

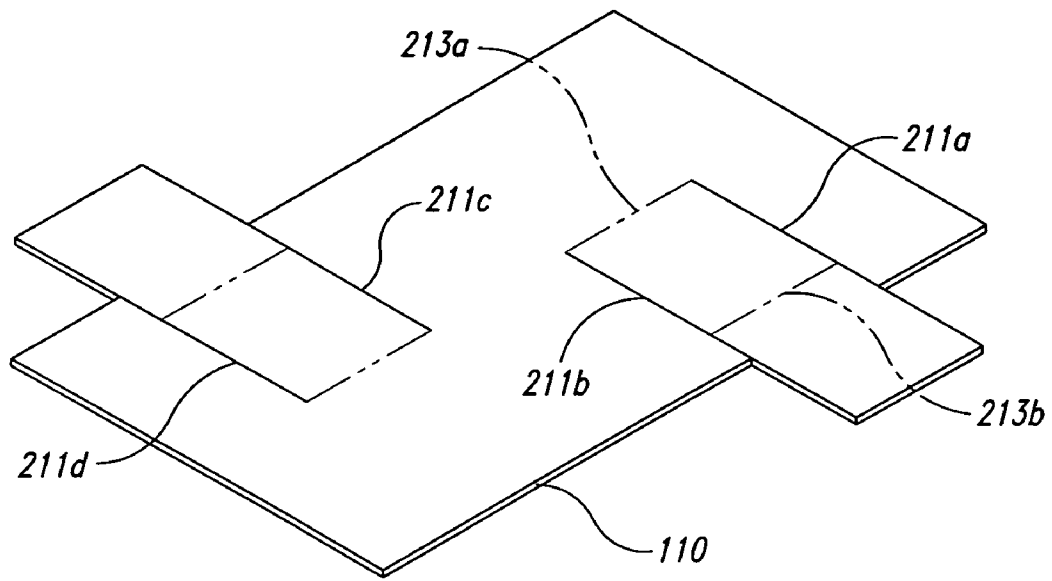

Fig. 2A

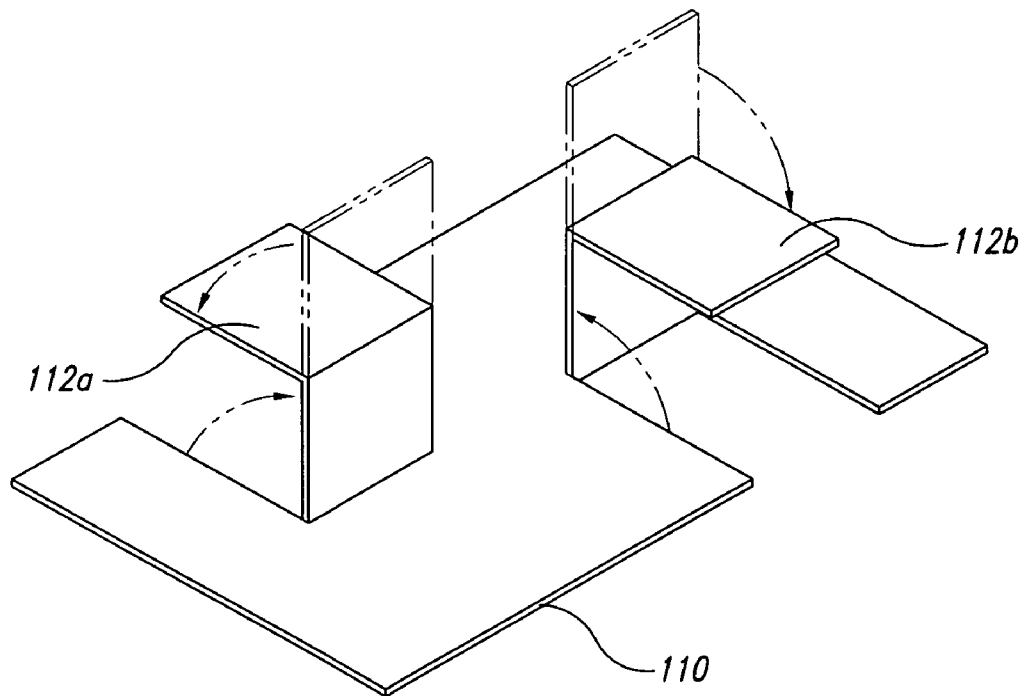

Fig. 2B

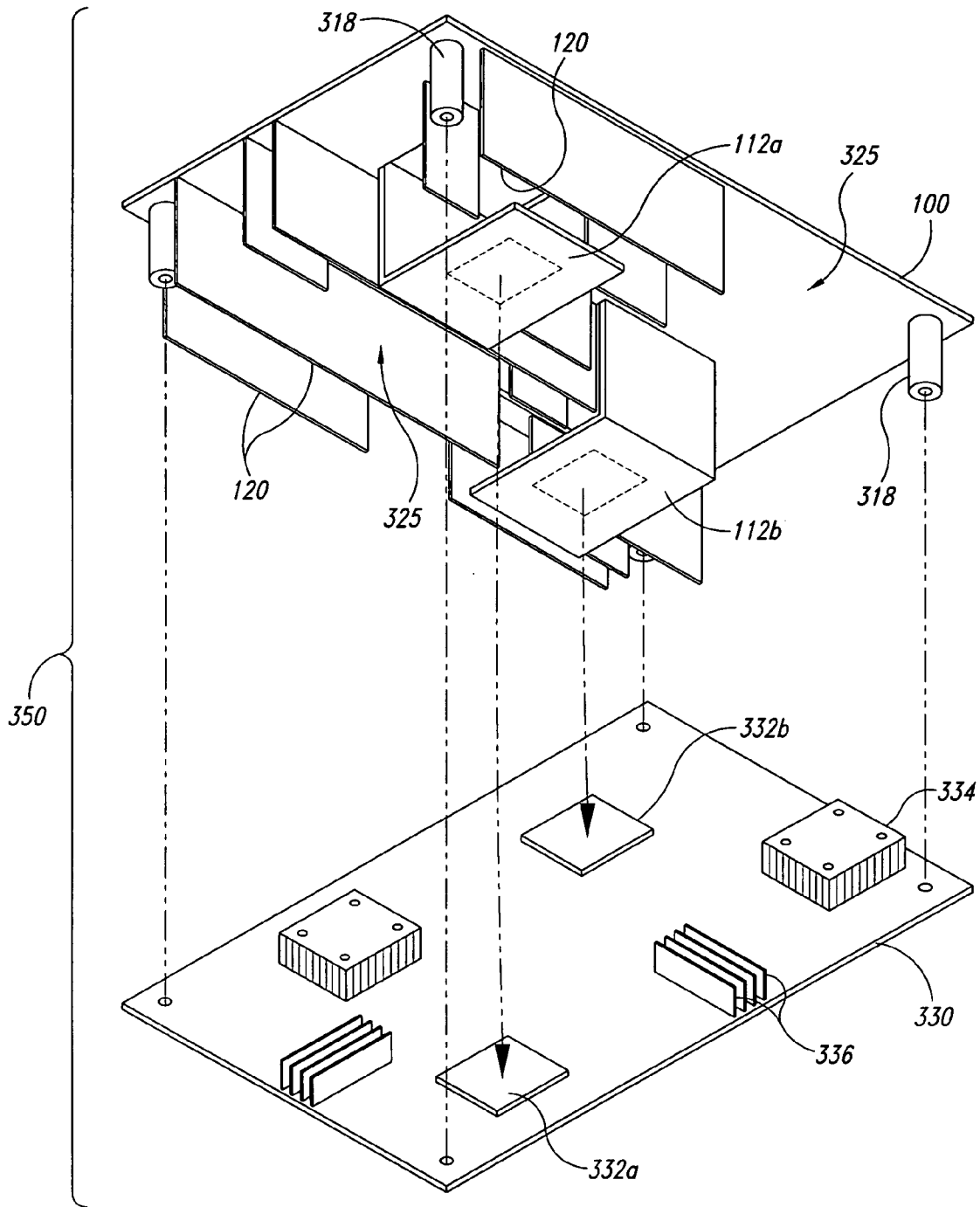

Fig. 3

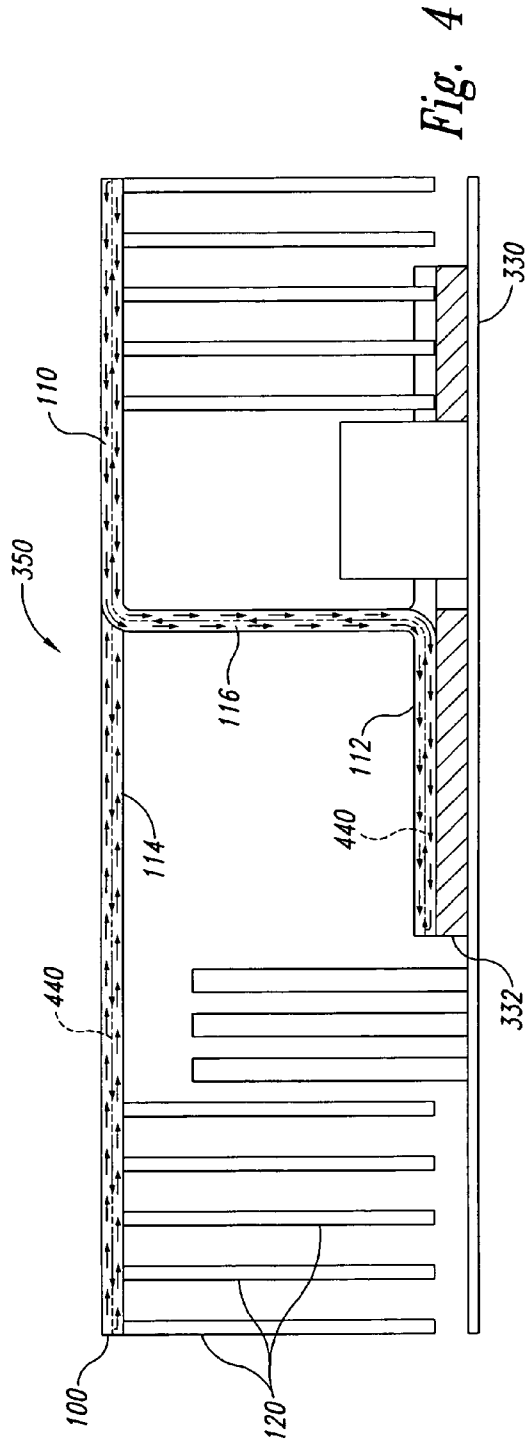

Fig. 4

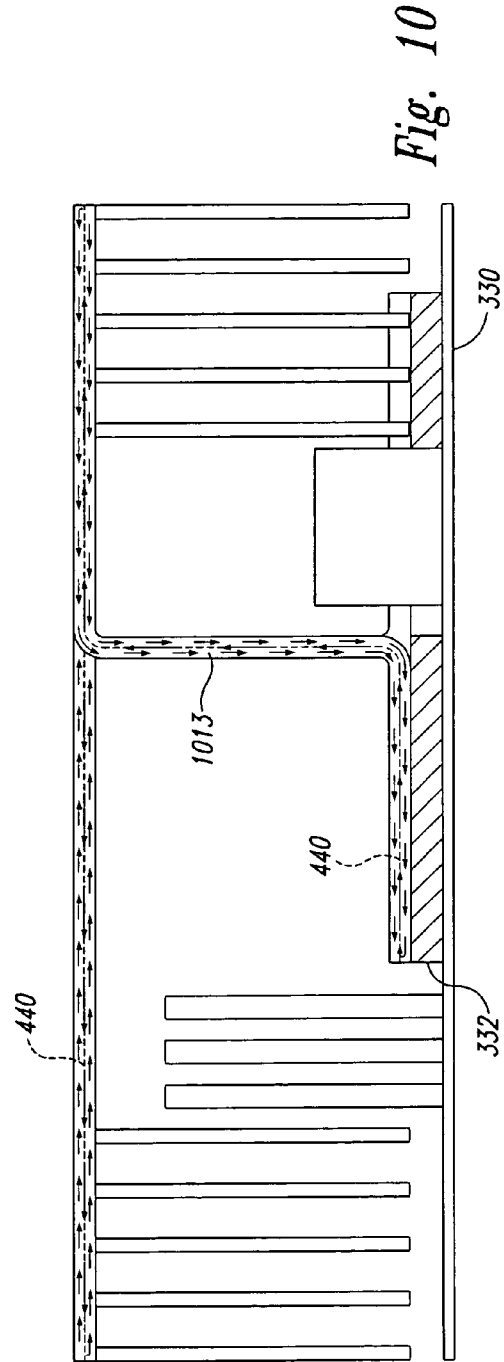

Fig. 10

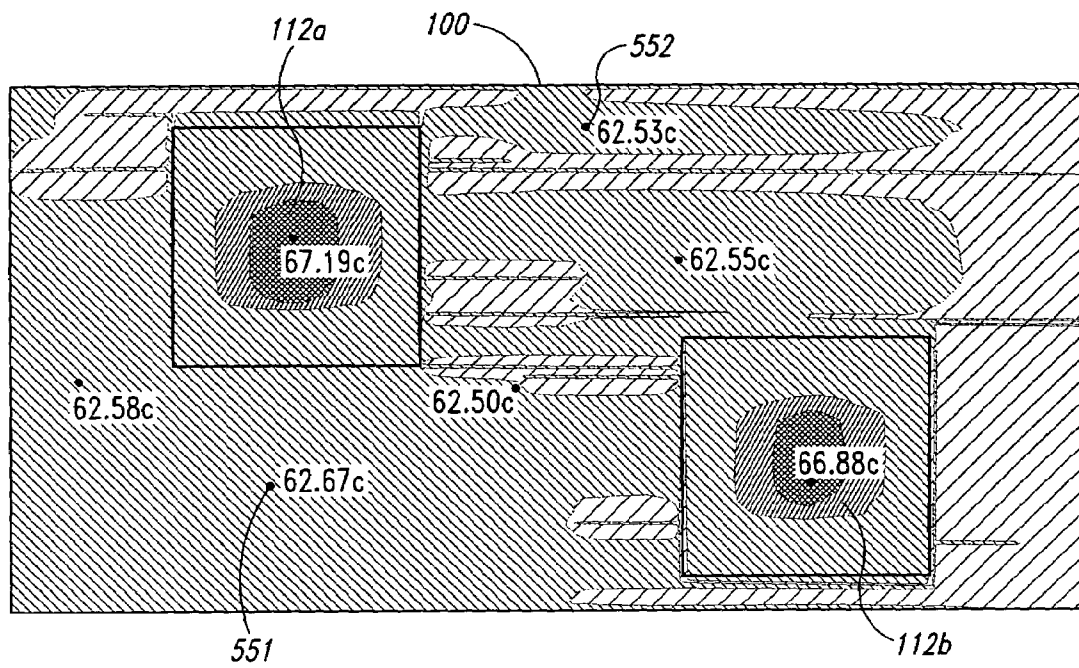

Fig. 5

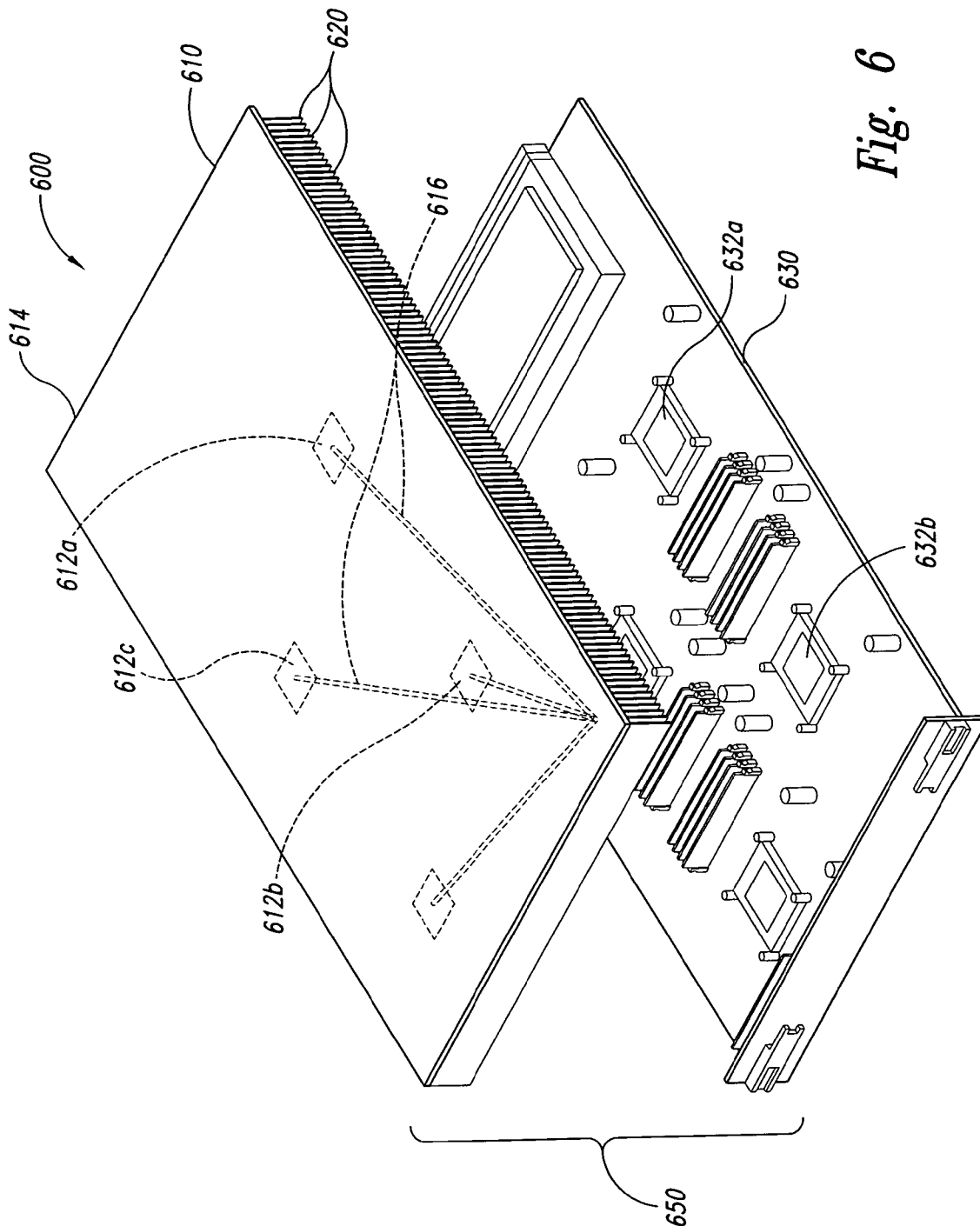

Fig. 6

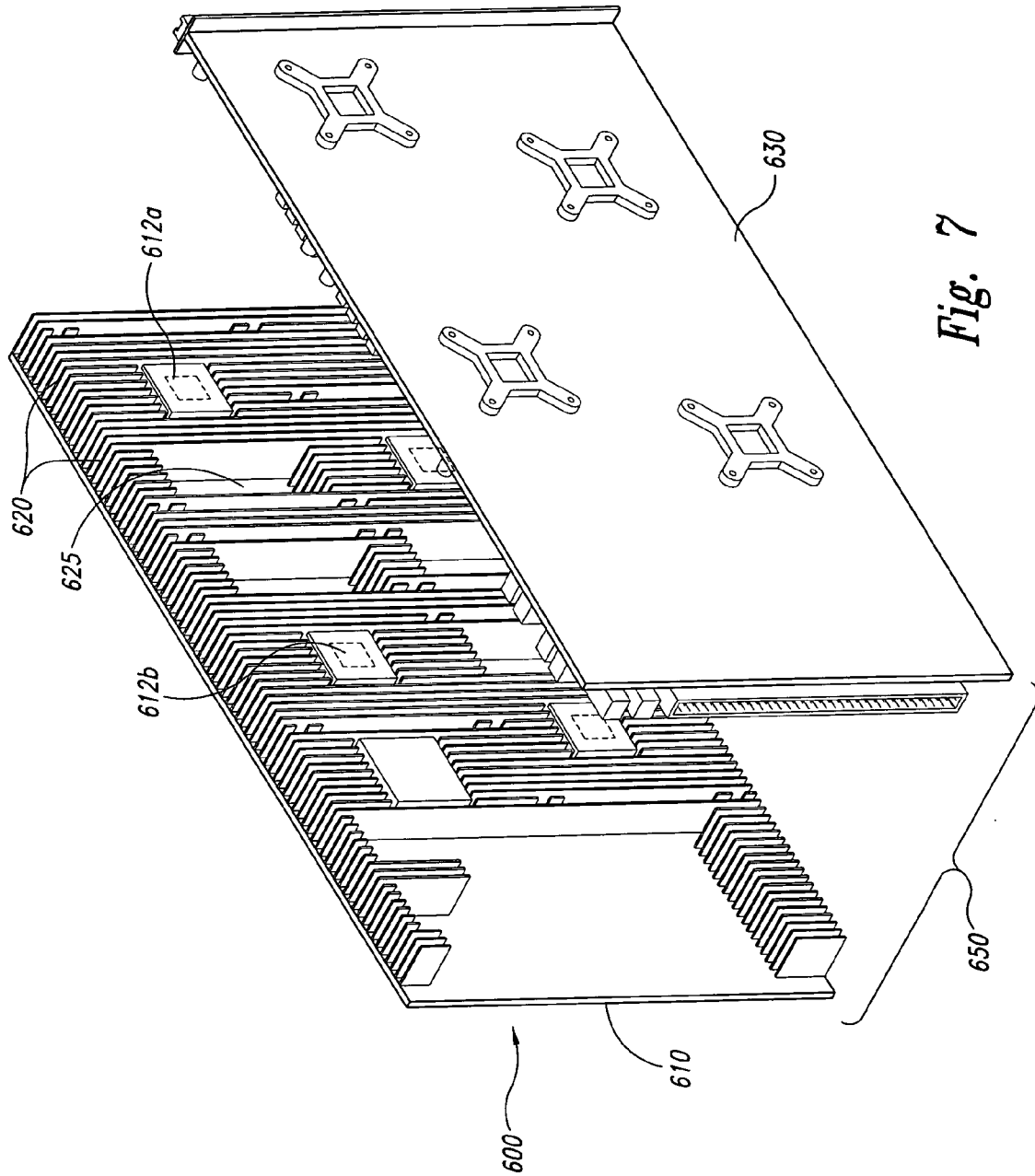

Fig. 7

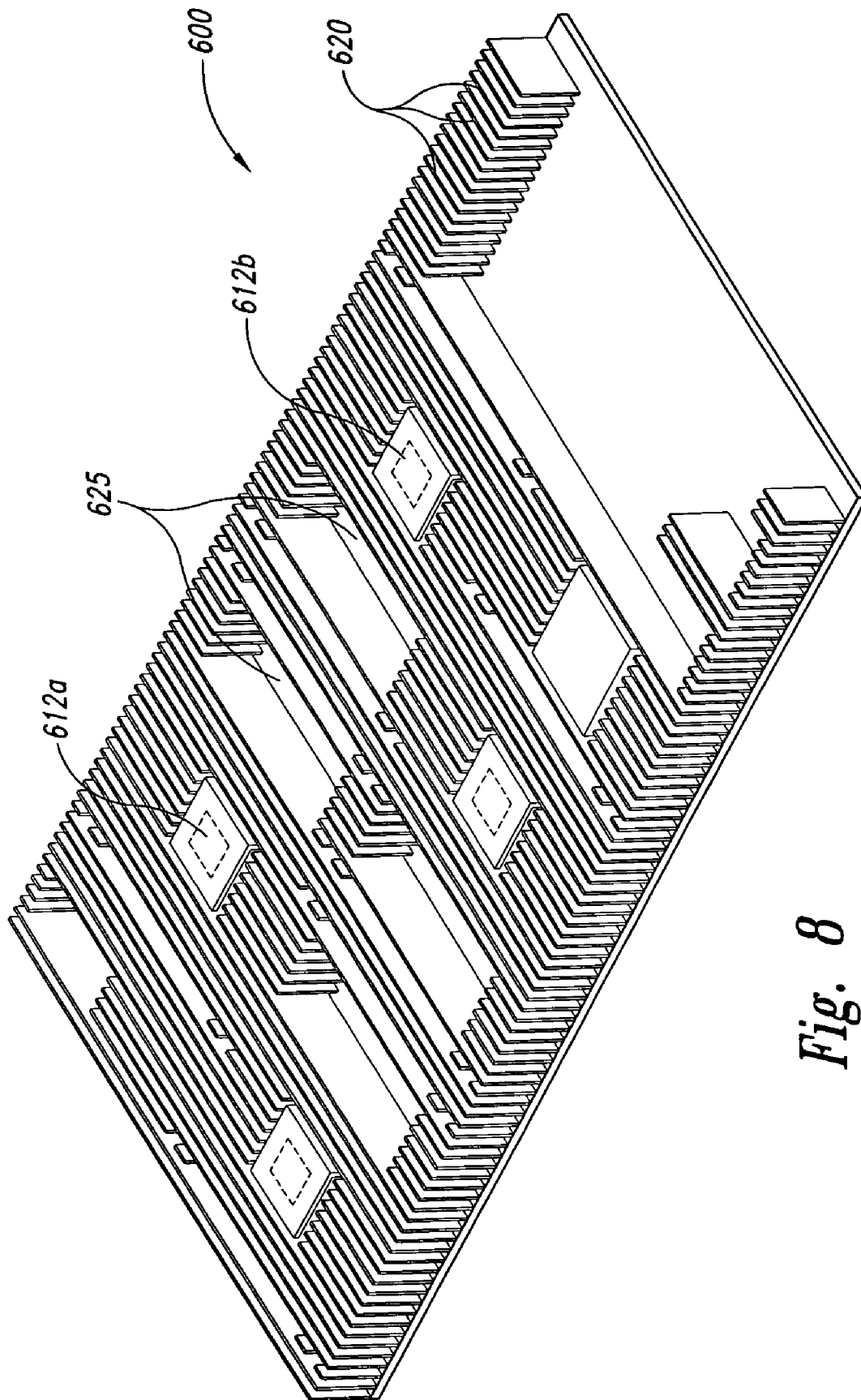

Fig. 8

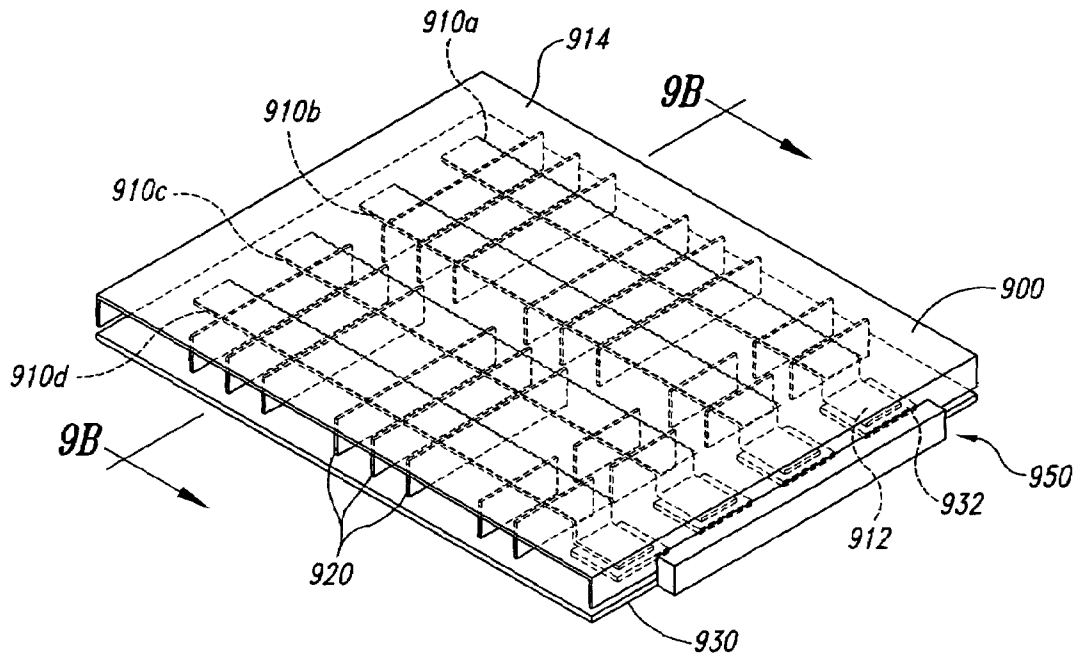

Fig. 9A

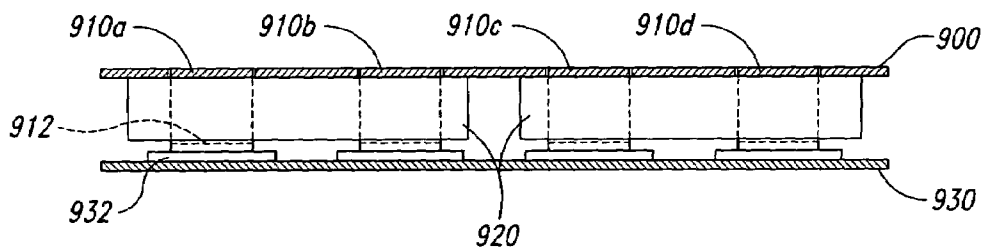

Fig. 9B

1

APPARATUSES AND METHODS FOR COOLING ELECTRONIC DEVICES IN COMPUTER SYSTEMS

CROSS-REFERENCE TO RELATED
APPLICATION(S) INCORPORATED BY
REFERENCE

This application claims the benefit of U.S. Provisional Application No. 60/579,401, filed on Jun. 14, 2004, entitled "METHODS AND APPARATUSES FOR COOLING ELECTRONIC DEVICES IN COMPUTER SYSTEMS," which is incorporated herein in its entirety by reference.

TECHNICAL FIELD

The following disclosure relates generally to apparatuses for cooling electronic devices in computer systems and, more particularly, to heat pipe systems for cooling electronic devices mounted to computer modules in large computer systems.

BACKGROUND

Supercomputers and other large computer systems typically include a large number of computer cabinets arranged in banks. Each of the computer cabinets typically holds a large number of computer modules positioned in close proximity to each other for high efficiency. Each of the computer modules can include a motherboard having a printed circuit or printed wiring assembly (PWA) electrically connecting a plurality of processors, routers, and other microelectronic devices together for data and/or power transmission.

Many of the electronic devices typically found in supercomputers, such as fast processing devices, generate considerable heat during operation. This heat can damage the device and/or degrade performance if not dissipated. Consequently, supercomputers typically include both active and passive cooling systems to maintain device temperatures at acceptable levels.

Various types of passive heat-dissipation devices, such as heat sinks and heat pipe systems, have been used to cool processors and other types of electronic devices typically found in computer systems. Conventional heat sinks typically include a plurality of cooling fins extending upwardly from a planar base structure. In operation, the planar base structure is held in contact with the electronic device and heat from the device transfers into the base and then the cooling fins. Air from a cooling fan or similar device can be directed over the cooling fins to dissipate the heat.

One problem associated with conventional heat sinks is that the heat generated by the electronic device tends to be localized in discrete areas. This leads to high thermal gradients across the heat sink. As a result, most of the heat is dissipated by the cooling fins located close to the hot regions of the device. Another shortcoming of conventional heat sinks is that the air flow rate through the cooling fins is often less than the flow rate around the heat sink—an effect commonly referred to as “overpass” or “sidepass.”

Heat-dissipation devices based on heat pipe technology typically operate on a closed, two-phase cycle that utilizes the latent heat of vaporization to transfer heat. One conventional heat pipe system for cooling processing devices includes a planar base consisting of a porous wick structure. The porous wick structure forms an envelope that is evacuated and backfilled with just enough working fluid to satu-

2

rate the wick structure. The pressure inside the envelope is set near the equilibrium pressure for liquid and vapor.

In operation, the base of the heat pipe system is held in contact with the electronic device, and heat from the device causes the local working fluid to evaporate at a pressure that is slightly higher than the equilibrium pressure. The high pressure vapor then flows away from the heat source to a cooler region of the base structure where the vapor condenses, giving up its latent heat of vaporization. The condensed fluid then moves back to the hot region of the base structure by capillary forces developed in the wick structure. This continuous cycle transfers large quantities of heat across the base structure with low thermal gradients. Like the heat sink described above, the heat pipe system can also include a plurality of cooling fins extending upwardly from the base structure to dissipate heat into a cooling air flow.

Another heat-pipe-based system that has been disclosed for cooling semiconductors is the heat spreading apparatus described in U.S. Pat. Nos. 6,158,502 and 6,167,948 to Thomas, both of which are incorporated herein in their entireties by reference. The heat spreading apparatus of Thomas includes a first planar body connected to a second planar body to define a void therebetween. The void includes a planar capillary path and a non-capillary region. The heat spreading apparatus dissipates heat by vaporizing a portion of working fluid in a hot region of the planar capillary path, condensing the fluid in a cool area of the non-capillary region, and moving the condensed fluid from the cool area of the non-capillary region to the hot region of the planar capillary path through capillarity.

The various heat pipe systems described above typically operate with lower thermal gradients than conventional, non-heat-pipe-based heat sinks. However, the efficiency of these systems is still limited by space constraints, air flow constraints, and/or other factors when used in large computer systems and other high density applications.

BRIEF DESCRIPTION OF THE DRAWINGS

FIG. 1 is an isometric view of a heat sink configured in accordance with an embodiment of the invention.

FIGS. 2A-2B illustrate a process for forming a heat pipe structure in accordance with an embodiment of the invention.

FIG. 3 is an exploded isometric view of a heat sink and a corresponding motherboard configured in accordance with an embodiment of the invention.

FIG. 4 is a cross-sectional elevation view showing a portion of the heat sink of FIG. 3 mounted to the motherboard.

FIG. 5 is a schematic top view of a computer simulation illustrating temperature gradients in a heat sink configured in accordance with an embodiment of the invention.

FIG. 6 is an exploded isometric view of a computer module assembly that includes a heat sink configured in accordance with another embodiment of the invention.

FIG. 7 is an exploded isometric view of the computer module assembly of FIG. 6 looking upwardly at a bottom portion of the heat sink.

FIG. 8 illustrates cooling fin cutouts in the heat sink of FIGS. 7 and 8.

FIGS. 9A-9B are isometric and end views, respectively, of a computer module assembly having a heat sink configured in accordance with another embodiment of the invention.

FIG. 10 is a cross-sectional view showing a portion of a heat sink that includes a convection driven siphon configured in accordance with an embodiment of the invention.

The following disclosure describes several embodiments of apparatuses and methods for cooling electronic devices mounted to motherboards and other structures. An apparatus for dissipating heat generated by a processor or other electronic device in accordance with one aspect of the invention includes a heat pipe structure. The heat pipe structure includes an interface portion offset from a body portion by a leg portion. The interface portion is configured to be positioned proximate to an electronic device, and the body portion is configured to be spaced apart from the electronic device. The heat pipe structure further includes a working fluid. The working fluid is positioned to absorb heat from the electronic device at the interface portion of the heat pipe structure and transfer the heat to the body portion of the heat pipe structure. In another aspect of the invention, the apparatus can further include at least one cooling fin attached to the body portion of the heat pipe structure. In this way, heat can be transferred away from the electronic device and dissipated by air flowing over the cooling fin.

A heat sink configured in accordance with another aspect of the invention is configured to spread the heat generated by an electronic device over a broader area than conventional heat sinks. Specifically, in this aspect of the invention, the heat sink can extend beyond the electronic device and over an adjacent portion of the motherboard or other mounting structure. In addition, the heat sink can include cooling fins that extend into gaps between other components mounted to the motherboard. This enables the heat sink to take advantage of relatively high velocity/low temperature air flows that may exist away from the electronic device.

Specific details of several embodiments of the invention are described below to provide a thorough understanding of such embodiments. Other details describing well-known structures and systems often associated with computers and related devices are not set forth below to avoid unnecessarily obscuring the description of the various embodiments. Those of ordinary skill in the art will understand that the invention may have other embodiments in addition to those described below with reference to the related Figures. Such embodiments may include elements other than those described below. In addition or alternatively, such embodiments may lack one or more of the elements described below.

In the Figures, identical reference numbers identify identical or at least generally similar elements. To facilitate the discussion of any particular element, the most significant digit or digits of any reference number refer to the Figure in which that element is first introduced. Element **210**, for example, is first introduced and discussed with reference to FIG. **2**.

FIG. **1** is an isometric view of a heat sink **100** configured in accordance with an embodiment of the invention. In one aspect of this embodiment, the heat sink **100** includes a heat pipe structure **110** and a plurality of cooling fins **120**. In the illustrated embodiment, the heat pipe structure **110** includes a plurality of interface portions **112** (identified individually as a first interface portion **112a** and a second interface portion **112b**) offset from a body portion **114** by corresponding leg portions **116** (identified individually as a first leg portion **116a** and a second leg portion **116b**). The cooling fins **120** extend from the body portion **114** of the heat pipe structure **110**.

In one embodiment, the heat pipe structure **110** can be formed from highly porous wick material **111** that is evacuated and contains a working fluid. For example, in one

embodiment, the highly porous wick material can include a 3-D decahedral structure forming vacuum chambers that contain the working fluid. Such wick materials can include copper, aluminum and other suitable materials. In another embodiment, the heat pipe structure **110** or portions thereof can include materials that are similar to, or the same as, the "IsoSkin" (or "IsoFilm") material provided by, e.g., Novel Concepts, Inc. of Las Vegas, Nev., USA. In a further embodiment, the heat pipe structure **110** or portions thereof can include materials that are similar to, or the same as, the "Therma-Base™" vapor spreader material provided by Thermacore International, Inc. of Lancaster, Pa., USA. In another aspect of this embodiment, the working fluid can include water, acetone, ammonia, methanol, or other suitable fluid.

As used throughout this disclosure, the term "heat sink" will be understood to include devices and/or assemblies that serve to dissipate, carry away, or radiate heat generated by an active electronic device into the surrounding atmosphere. Further, the term "heat pipe structure" will be understood to include structures that contain one or more evacuated cavities, vessels or capillaries which are partially back-filled with a working fluid. Such structures can transfer heat by an evaporation/condensation cycle of the working fluid. As heat is absorbed from an electronic device or other heat source, the working fluid is vaporized, creating a pressure gradient in the heat pipe structure. The pressure gradient forces the vapor to flow outwardly from the heat source to a cooler region of the heat pipe structure where it condenses, giving up its latent heat of evaporation. The working fluid then cycles back to the evaporator portion of the heat pipe structure by capillary forces, gravity, and/or other means. Such processes can also be referred to as "thermosyphon" processes. One advantage of using a heat pipe structure to transfer heat in this manner is that such structures are typically very efficient and have high thermal conductance.

As described in greater detail below, in operation, the interface portions **112** of the heat sink **100** are positioned in contact with, or at least proximate to, electronic devices, such as computer processors, mounted on a computer module. Heat from the electronic devices is transferred to the interface portions **112**, causing the working fluid in these regions to evaporate. The evaporated working fluid then moves away from the interface portions **112** to the body portion **114** via the leg portions **116**. In the body portion **114**, heat from the working fluid transfers into the cooling fins **120**, causing the working fluid to condense and return to the interface portions **112** as part of a continual cycle.

FIGS. **2A-2B** illustrate one process for manufacturing the heat pipe structure **110** described above with reference to FIG. **1** in accordance with an embodiment of the invention. Referring first to FIG. **2A**, the heat pipe structure **110** starts as a relatively planar piece of heat pipe material (e.g., porous wick material, IsoFilm, IsoSkin, Therma-Base™, or other suitable material that provides efficient heat transfer with relatively low thermal gradients). Four incisions are made along cut-lines **211a-211d**. The two portions of material between the cut-lines **211a-b** and **211c-d** are then folded up about a first fold line **213a** and then down about a second fold line **213b** to form the interface portions **112** as illustrated in FIG. **2B**. After this operation, the cooling fins **120** (FIG. **1**) can be joined to the heat pipe structure **110** by solder bonding, adhesive bonding, or other suitable method. In other embodiments, the cooling fins **120** can be integrally formed with the heat pipe structure **110**.

FIG. **3** is an exploded isometric view of a computer module assembly **350** configured in accordance with an

5

embodiment of the invention. The computer module assembly **350** includes a motherboard **330** to which the heat sink **100** is mounted. The motherboard **330** includes a plurality of electronic devices, including memory devices **336**, routing devices **334**, and a plurality of processing devices **332** (illustrated as a first processing device **332a** and a second processing device **332b**).

In FIG. **3**, the heat sink **100** is illustrated in an inverted position relative to FIG. **1**. As shown, the heat sink **100** can include a plurality of risers **318** and/or other locating devices to position the interface portions **112** of the heat pipe structure **110** at least proximate to the corresponding processing devices **332** when the heat sink **100** is mounted to the motherboard **330**. In one embodiment, the interface portions **112** can be held in contact with the corresponding processing devices **332** for efficient heat transfer. The cooling fins **120** can include a number of cutout areas **325** to provide adequate clearance for the various devices mounted to the motherboard **330**. For example, the cooling fins **120** can include cutouts and/or other spatial accommodations for the memory devices **336** and the routing devices **334**.

In one embodiment, the computer module **350** can be used in a computer cabinet for a supercomputer or other large computer system. Examples of such computer cabinets and related systems are disclosed in copending U.S. patent application Ser. Nos. 10/805,875, filed Mar. 22, 2004; Ser. No. 10/862,031, filed Jun. 4, 2004; and Ser. No. 10/886,911, filed Jul. 8, 2004. Each of these patent applications is incorporated herein in its entirety by reference. However, heat sinks configured in accordance with the present disclosure are not limited to use in such computer cabinets. In other embodiments, heat sinks configured in accordance with the present disclosure can be used for cooling other types of electronic devices in other types of computer systems and/or other types of electrical systems.

FIG. **4** is a cross-sectional elevation view of a portion of the computer module assembly **350** of FIG. **3**, illustrating the heat sink **100** mounted to the motherboard **330**. The interface portions **112** of the heat pipe structure **110** contact the corresponding processing devices **332**. The cooling fins **120** extend downwardly from the body portion **114** of the heat sink **100** toward the motherboard **330**. In operation, working fluid **440** proximate to the interface portion **112** absorbs heat from the processing device **332**. The heat causes the working fluid **440** to evaporate. The increased pressure from the evaporation process drives the evaporated portion of the working fluid **440** away from the interface portion **112** and into the body portion **114** via the leg portion **116**. The heated working fluid expands outwardly in the body portion **114**, conducting heat to the cooling fins **120**. The heat is dissipated by the cooling fins **120**, causing the working fluid **440** to condense. The condensed working fluid **440** then recirculates back to the interface portion **112** through capillary action or otherwise in a continual cooling cycle.

Although, in one embodiment, the heat sink **100** can utilize a porous wick structure to cycle working fluid, in other embodiments, other systems and methods can be used for this purpose. For example, in various embodiments, heat sinks configured in accordance with the present disclosure can include a convection driven siphon **1013** (see FIG. **10**), pumps (e.g., a reverse osmosis pump or a magnetic drive pump using water, a refrigerant, or other agent, etc.), and/or liquid metal nanofluid driven by an electromagnetic pump. Accordingly, the present invention is not limited to the use of porous wick structures, but extends to other suitable cooling technologies.

6

One feature of the heat sink **100** described above is that the cooling fins **120** are not constrained to the local area around the processing devices **332**, but instead are able to expand into much of the open space around the motherboard **330**. One advantage of this feature is that it can provide more efficient device cooling by taking advantage of higher velocity and/or lower temperature air flows near other parts of the computer module **350**. Another advantage of this feature is that it increases the overall surface area of the cooling fins **120**.

FIG. **5** is a schematic top view illustrating temperature gradients across a computer model of the heat sink **100** in accordance with an embodiment of the invention. In this computer simulation, the temperature of the heat sink **100** proximate to the interface portions **112** is seen to be about 67° C. Moving outwardly from the interface portions **112**, the heat is efficiently conducted to other regions of the heat sink **100** for dissipation via the cooling fins **120** (not shown). For example, the temperatures at a first point **551** and a second point **552** spaced apart from the interface portions **112** are about 63° C. The relatively small temperature gradient between the interface portions **112** and the first and second points **551**, **552** illustrates the thermal efficiency of the heat sink **100** in the illustrated embodiment.

FIG. **6** is an exploded isometric view of a computer module assembly **650** that includes a motherboard **630** and a heat sink **600** configured in accordance with another embodiment of the invention. The motherboard **630** can be at least generally similar in structure and function to the motherboard **330** described above with reference to FIG. **3**. Accordingly, the motherboard **630** can include a first processing device **632a** and a second processing device **632b**.

The heat sink **600** can include a plurality of cooling fins **620** extending downwardly from a heat pipe structure **610**. In one aspect of this embodiment, the heat pipe structure **610** can include a plurality of evaporators **612** (identified individually as a first evaporator **612a**, a second evaporator **612b**, and a third evaporator **612c**). In the illustrated embodiment, each of the evaporators **612** can include a microchannel heat exchanger (e.g., one or more heat pipes and/or vapor chambers) that absorbs heat from the corresponding processing device **632** and evaporates working fluid enclosed therein. The evaporated working fluid then flows outwardly away from the evaporators **612** via corresponding fluid paths **616**. As it does so, the evaporated working fluid is disbursed throughout a body portion **614** of the heat pipe structure **610** (which may include additional microchannels and/or a cold plate) to condense the working fluid before returning to the evaporators **612**.

FIG. **7** is an exploded isometric view of the computer module assembly **650** of FIG. **6**, looking upwardly at a bottom portion of the heat sink **600**. The interface portions **612** of the heat pipe structure **610** extend downwardly from the body portion **614** toward the corresponding processing devices **632** (FIG. **6**). The heat pipe structure **610** also includes a plurality of cutouts **625** formed in the cooling fins **620** to accommodate various devices mounted to the motherboard **630**. The cutouts **625** and the interface portions **612** are further illustrated in FIG. **8**.

FIG. **9A** is an isometric view of a computer module assembly **950** having a heat sink **900** configured in accordance with another embodiment of the invention. FIG. **9B** is a cross-sectional end view taken along line **9B-9B** in FIG. **9A**. Referring to FIGS. **9A** and **9B** together, the heat sink **900** of this embodiment includes a plurality of individual heat pipe structures **910** (identified individually as heat pipe structures **910a-d**) mounted to a body portion **914**. A plu-

rality of cooling fins **920** extend downwardly from the body portion **914** toward a motherboard **930**, as shown in FIG. **9B**. In the illustrated embodiment, the heat pipe structures **910** each include an interface portion **912** that contacts a corresponding processing device **932** mounted to the motherboard **930**. The interface portions **912** of the heat pipe structures **910** joggle upwardly from the motherboard **930** and attach to the body portion **914** of the heat sink **900**.

In operation, heat from the processing devices **932** is transferred into the interface portions **912** of the heat pipe structures **910**. This heat causes working fluid (not shown) contained within the interface portions **912** to evaporate. The evaporated working fluid then flows away from the interface portions **912** and into those portions of the heat pipe structures **910** which are carried by the body portion **914** of the heat sink **900**. The cooling fins **920** dissipate heat from the working fluid, causing the working fluid to condense and return to the interface portions **912**.

From the foregoing, it will be appreciated that specific embodiments of the invention have been described herein for purposes of illustration, but that various modifications may be made without deviating from the spirit and scope of the invention. For example, although many of the heat sinks described above include closed heat pipe systems that passively circulate working fluids, other embodiments of the invention can include active systems for circulating working fluid. For example, in one embodiment, a pump can be used to circulate working fluid from an external source through a heat sink assembly similar to those described above.

Furthermore, aspects of the invention described above in the context of particular embodiments may be combined or eliminated in other embodiments. In addition, while advantages associated with certain embodiments of the invention have been described in the context of those embodiments, other embodiments may also exhibit such advantages, and not all embodiments need necessarily exhibit such advantages to fall within the scope of the invention. Accordingly, the invention is not limited, except as by the appended claims.

I claim:

1. A heat sink for dissipating heat generated by an electronic device in a computer system, the heat sink comprising:

a heat pipe structure formed from a single piece of heat pipe material having a plurality of evacuated passages, the heat pipe structure including:

a planar interface portion configured to be positioned proximate to the electronic device;

a planar leg portion extending away from the interface portion, wherein the leg portion is at least generally perpendicular to the interface portion, and wherein the interface portion extends away from the leg portion in a first direction;

a planar body portion vertically offset from the interface portion by the leg portion, wherein the body portion is at least generally parallel to the interface portion, and wherein the body portion includes a first portion of the evacuated passages which extends away from the leg portion in the first direction and a second portion of the evacuated passages which extend away from the leg portion in a second direction, the second direction being opposite to the first direction; and

a working fluid that cycles through the evacuated passages of the heat pipe material to absorb heat from the electronic device at the interface portion of

the heat pipe structure and transfer the heat to the body portion of the heat pipe structure.

2. The heat sink of claim **1**, further comprising at least one cooling fin attached to the body portion of the heat pipe structure.

3. The heat sink of claim **1**, further comprising a plurality of coplanar cooling fins attached to the body portion of the heat pipe structure.

4. The heat sink of claim **1**, further comprising at least one cooling fin attached to the body portion of the heat pipe structure, wherein the body portion of the heat pipe structure is vertically offset from the interface portion in a third direction, and wherein the at least one cooling fin extends away from the body portion in a fourth direction, opposite to the third direction.

5. The heat sink of claim **1** wherein the heat pipe structure further includes at least one internal passage extending from the interface portion to the body portion, and wherein at least a portion of the working fluid is contained in the internal passage.

6. The heat sink of claim **1** wherein the heat pipe structure includes a plurality of capillaries through which the working fluid circulates.

7. A heat sink for dissipating heat generated by an electronic device in a computer system, the heat sink comprising:

a heat pipe structure, the heat pipe structure including:

an interface portion configured to be positioned proximate to the electronic device;

a leg portion extending away from the interface portion, wherein the leg portion is at least generally perpendicular to the interface portion, and wherein the interface portion extends away from the leg portion in a first direction;

a body portion vertically offset from the interface portion by the leg portion, wherein the body portion is, wherein the body portion has a planar surface that is at least generally parallel to the interface portion and substantially larger than the interface portion, and wherein the planar surface extends away from the leg portion in the first direction and a second direction, the second direction being opposite to the first direction; and

a working fluid positioned to absorb heat from the electronic device at the interface portion of the heat pipe structure and transfer the heat to the body portion of the heat pipe structure, wherein the heat pipe structure includes a thermosyphon that carries at least a portion of the working fluid through a plurality of fluid passages in the body portion that extend away from the leg portion in the first direction and the second direction.

8. The heat sink of claim **1** wherein the heat pipe structure includes a porous wick structure that carries at least a portion of the working fluid.

9. The heat sink of claim **1** wherein the heat pipe structure includes a convection driven siphon that carries at least a portion of the working fluid.

10. The heat sink of claim **1** wherein the interface portion of the heat pipe structure is a generally planar structure.

11. The heat sink of claim **1** wherein interface portion and the body portion of the heat pipe structure are generally coplanar structures.

12. A heat sink for dissipating heat generated by an electronic device in a computer system, the heat sink comprising:

9

a heat pipe structure, the heat pipe structure including:
 a first interface portion configured to be positioned proximate to a first electronic device, wherein the first interface portion is formed from heat pipe material having a plurality of evacuated passages; 5
 a body portion offset from the first interface portion by a first leg portion, wherein the body portion is configured to be spaced apart from the first electronic device, and wherein the body portion and the first leg portion are formed from the same heat pipe material as the first interface portion; 10
 a working fluid that cycles through the evacuated passages of the heat pipe material to absorb heat from the first electronic device at the first interface portion of the heat pipe structure and transfer the heat to the body portion of the heat pipe structure; and 15
 a second interface portion offset from the body portion by a second leg portion, wherein the second interface portion is configured to be positioned proximate to a second electronic device. 20

13. A computer module assembly comprising:
 a motherboard;
 an electronic device mounted to the motherboard; and
 a heat sink configured to dissipate heat generated by the electronic device, the heat sink including a heat pipe structure having:
 an interface portion positioned proximate to the electronic device, wherein the interface portion is formed from heat pipe material having a plurality of evacuated passages;
 a leg portion extending away from the interface portion, wherein the leg portion is at least generally perpendicular to the interface portion, and wherein the interface portion extends away from the leg portion in a first direction;
 a body portion offset from the interface portion by the leg portion, wherein the body portion is spaced apart from the electronic device, wherein the body portion and the leg portion are formed from the same heat pipe material as the interface portion, and wherein the body portion includes a first portion of the evacuated passages that extends away from the leg portion in the first direction and a second portion of the evacuated passages that extend away from the leg portion in a second direction, the second direction being opposite to the first direction; and 45
 a working fluid that cycles through the evacuated passages in the heat pipe material to absorb heat from the electronic device and transfer the heat to the body portion of the heat pipe structure. 50

14. The computer module assembly of claim **13**, wherein the heat pipe structure further includes a plurality of cooling fins extending away from the body portion toward the motherboard.

15. A computer module assembly comprising:

a motherboard;
 a first electronic device mounted to the motherboard;
 a heat sink configured to dissipate heat generated by the first electronic device, the heat sink including a heat pipe structure having:
 a first interface portion positioned proximate to the first electronic device, wherein the first interface portion is formed from heat pipe material having a plurality of evacuated passages;
 a body portion offset from the first interface portion by a leg portion, wherein the body portion is spaced apart from the first electronic device, and wherein the

10

body portion and the leg portion are formed from the same heat pipe material as the first interface portion; and
 a working fluid that cycles through the evacuated passages in the heat pipe material to absorb heat from the first electronic device and transfer the heat to the body portion of the heat pipe structure, and
 a second electronic device mounted to the motherboard, wherein the heat pipe structure further includes a second interface portion spaced apart from the first interface portion and positioned proximate to the second electronic device.

16. A computer module assembly comprising:
 a motherboard;
 a first electronic device mounted to the motherboard;
 a second electronic device mounted to the motherboard;
 a heat sink configured to dissipate heat generated by the first electronic device, the heat sink including a heat pipe structure having:
 a first interface portion positioned proximate to the first electronic device; a body portion offset from the first interface portion by a leg portion, wherein the body portion is spaced apart from the first electronic device;
 a working fluid positioned to absorb heat from the first electronic device and transfer the heat to the body portion of the heat pipe structure;
 a second interface portion spaced apart from the first interface portion and positioned proximate to the second electronic device; and
 a plurality of cooling fins extending from the body portion toward the motherboard between the first and second interface portions.

17. A system for dissipating heat generated by an electronic device mounted to a motherboard, the system comprising:

means for transferring heat from the electronic device into a working fluid to thereby cause at least a portion of the working fluid to evaporate;
 means for conveying at least a portion of the evaporated working fluid away from the motherboard in a first direction; and
 means for transferring heat from the evaporated working fluid into a plurality of cooling fins extending toward the motherboard in a second direction opposite to the first direction, wherein the plurality of cooling fins include a first portion of cooling fins spaced apart from a second portion of cooling fins, wherein the first portion of cooling fins is offset from a first side of the means for conveying and the second portion of cooling fins is offset from a second side of the means for conveying, and wherein transferring heat from the evaporated working fluid into the plurality of cooling fins causes at least a portion of the evaporated working fluid to condense.

18. The system of claim **17** wherein the means for conveying at least a portion of the evaporated working fluid away from the motherboard include a plurality of capillaries.

19. The system of claim **17**, further comprising means for returning at least a portion of the condensed working fluid to a position proximate the electronic device.

20. The system of claim **19** wherein the means for returning include a porous wick structure.

21. A method for cooling an electronic device in a computer system, the method comprising:
 forming an interface portion, a leg portion, and a body portion of a heat sink from a single piece of heat pipe material having a plurality of evacuated passages;

11

positioning the interface portion of the heat sink at least proximate to a surface of the electronic device, wherein the interface portion of the heat sink is vertically offset from the body portion of the heat sink by the leg portion, wherein the interface portion extends away from the leg portion in a first direction, and wherein the body portion includes a first portion of the evacuated passages that extends away from the leg portion in the first direction and a second portion of the evacuated passages that extend away from the leg portion in a second direction, the second direction being opposite to the first direction, and wherein the heat sink further includes a working fluid positioned to absorb heat from the electronic device and transfer the heat to the body portion of the heat sink via the first and second portions of the evacuated passages; and

12

moving air past a plurality of cooling fins extending from the body portion of the heat sink.

22. The method of claim **21** wherein positioning an interface portion of a heat sink at least proximate to a surface of the electronic device includes positioning the interface portion of the heat sink in contact with the surface of the electronic device.

23. The method of claim **21** wherein the body portion of the heat sink is vertically offset from the interface portion of the heat sink in a third direction, and wherein moving air past the plurality of cooling fins includes moving air past a plurality of cooling fins extending away from the body portion of the heat sink in a fourth direction opposite to the first direction.

* * * * *